

Electronic Pressure Transducer

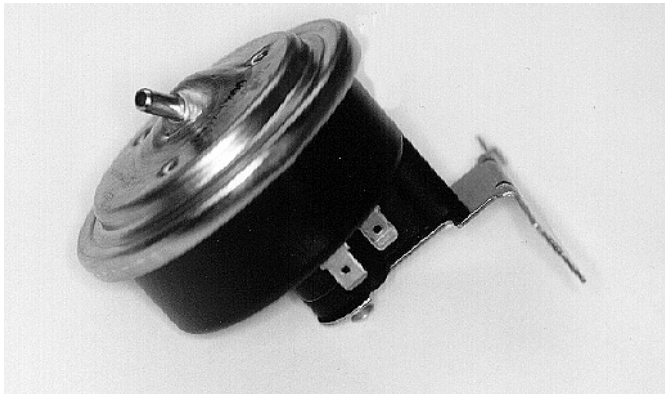

The pressure-actuated transducer is a non-contact sensor developed for use in electronically controlled clothes washers. The device interfaces with the washer's on-board electronics in monitoring the water fill levels. It provides a square-wave output signal with its frequency proportional to a change in water level height. This analog signal is fed to a microprocessor for control of the water inlet valve.

The device contains a flexible diaphragm that moves in response to changes in pressure. It also contains a magnetic coil attached to a printed circuit board that mounts the electronic components. Attached to the flexible diaphragm is a non-magnetic shading plate that is positioned in the magnetic field of the coil. Movement of the shading plate in toleration to the energized coil changes the level of inductance in the magnetic field and shifts the resonant frequency of the circuit.

The transducer can be programmed for various frequency range requirements. A secondary electrical switch can be added to provide redundant flood safety protection.

Features:

- Developed specifically for interfacing with a microprocessor
- Non-contact operation for long, reliable performance
- Flood Safety Switch available on request
- Available in a wide range of frequencies
- Listed with both UL and CSA

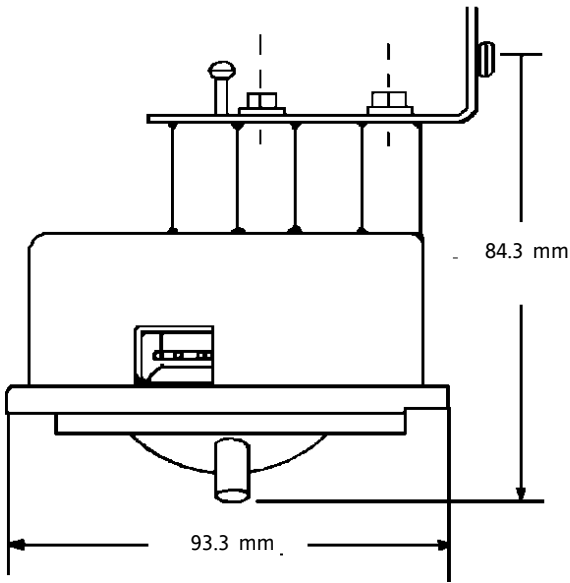

Specifications:

- Electrical Circuit Rating: 5 VDC, 10 MA
- Electrical Mechanical Switch Rating: 120 VAC, 1 Amp, 50/60 Hz
- Electronic Circuit Terminals: Pin type, JST B3PS-VR
- Electronic Mechanical Switch Rating: 6.4 Male Spade Brass
- Electronic Circuit Construction: Non-Contact Mechanical Switch, SPST, N/C, Snap Action
- PC Board: 0.062 CEM-1 Confirmed Coated
- Max Rated Pressure: 1.5 PSI / 0.01 mPa / 0.1 atm
- Operating Pressure: 0 to 25 inches W.C. / 0 to 0.006 mPa / 0 to 0.06 atm
- Electronic Frequency Output Differential: Less than 2%
- Mechanical Switch: 3 inches W.C. / 758 Pa / 0.0075 atm
- Mounting: Per Customer Specification
- Storage Temperature: 40-200° F / 4.4-93.3° C
- Operating Temperature: 35-65° F / 1.6-73.8° C
- Electronic Durability: Non-Contact 500,000 Cycles, Mechanical Switch 40,000